

11 EER 1.5-5 Ton Vertical Packaged Wall Mount Heat Pumps

EAA20-24-30-36-42-48-60 (High Efficiency Single Stage Cooling)

General Description

The Eubank® EAA family of wall mounted heat pumps are the ideal HVAC system for a wide variety of applications. The exterior mounting means that no valuable interior space is required. Eubank EAA heat pumps are packaged units – the refrigerant piping and internal wiring are factory assembled and thoroughly tested. All components are readily accessible for easy service and maintenance. The energy efficient operation keeps operating costs to a minimum and makes the Eubank heat pumps ideal problem solvers for a wide variety of applications, including offices, classrooms and telecommunication shelters.

Eubank heat pumps meet all federal efficiency requirements with an Energy Efficiency Ratio (EER) of 11. The Eubank EAA is available in cooling capacities of 1½, 2, 2½, 3, 3½, 4, and 5 tons (20,000 to 60,000 BTUH).

➤ Outside Air for Ventilation or Free Cooling

A full range of accessories and options allows Eubank heat pumps to be optimized for each application. For classrooms, a complete range of ventilation options are available to meet the fresh air requirements of the ASHRAE 62 standard, "Ventilation for Acceptable Indoor Air Quality". Where cooling is required during cool or cold weather, e.g., telecommunications shelters, a factory installed economizer should be used. To insure proper operation and optimum performance, all outside air ventilation packages are non-removable, factory installed and factory calibrated.

➤ Safety Listed and Energy Certified

All Eubank heat pumps are built to UL standard 1995, 4th edition and CAN/CSA C22.2, No. 236-11. For energy efficiency and performance, the units are tested and rated in accordance to the ANSI/AHRI (Air-Conditioning Heating and Refrigeration Institute) Standard 390 (Single Package Vertical Units). All units meet or exceed the efficiency requirements of ANSI/ASHRAE/IESNA 90.1.2016.

Eubank heat pumps are commercial units and are not intended for use in residential applications



EAA1036HA



FEATURES AND BENEFITS

Meets DOE Efficiency Requirements

- All Models 11EER
- All Models 3.3 COP

R-410A Refrigerant

- Efficient Heat Release
- Non-Ozone Depleting Refrigerant
- Synthetic Lubricant
- Reduced Compressor Wear

High Efficiency and Reliability

- No Wall Mount Heat Pump is More Efficient
- Optional Economizer Reduces Energy Usage
- High Efficiency Compressor and Lanced Coil Fins
- High/Low Pressure Switches with Lockout & Short Cycle Protection

Ease of Installation and Service

- Single Point Power Entry
- Built-In Mounting Flanges and Internal Disconnect
- Standard Access Valves and Filters, Status LEDs

Eubank Heat Pump Features

► High Efficiency

- Scroll compressors are standard on all units.
- Lanced fins and rifled tubing on the indoor & outdoor coils maximize heat transfer.
- Electronically commutated indoor blower motor on all models

► Engineered Reliability

- PC board simplifies wiring, consolidates several of the electrical functions in one device.
- High refrigerant pressure switch with lockout relay protects the compressor in the event of insufficient condenser air flow.
- Loss of charge pressure switch with lockout relay protects the compressor in the event of a loss of refrigerant or inadequate evaporator air flow.
- Time delay for short cycle protection.

► Ease of Installation

- Sloped top with flashing eliminates need of rain hood.
- Built-in mounting flanges facilitate installation and minimize chance of water leaks.
- Factory installed phase monitor is standard on all 3Ø units and will turn the air conditioner off if power supply is not phased properly.
- Factory installed disconnect on all units, including 460v. models.
- Outside air hood included with each unit.
- Single Point Power Entry complies with latest edition of U.L. Standard 1995.

► Rugged Construction

- Baked on finish over galvaneel steel on exterior sheet metal.
- Copper tube, aluminum fin evaporator and condenser coils.
- Corrosion resistant Dacromet® external fasteners.

► Ease of Service

- LED's on the control board indicate operational status and fault conditions.
- Refrigerant access valves are standard
- All major components are readily accessible
- Front control panel allows easy access and complies with NEC clearance codes on side by side units.
- Major components accessible from either side.



Options for Outside Air for Ventilation

ASHRAE standard 62 requires 30 cfm of outside air per occupant of a classroom. To meet this requirement, Eubank offers seven ventilation packages for every budget and requirement.

► Configuration "N": Manual Fresh Air Damper (*Standard*)

Manual damper capable of up to 15% of rated airflow of outside air; field adjustable, no pressure relief.

► Configuration "Y": Field Adjustable Manual Damper (*Optional*)

Manually field adjustable to allow up to 450 cfm, or 40% of the heat pump's total rated airflow of outside air.

► Configuration "Z": Field Adjustable Manual Damper with Pressure Relief (*Optional*)

Manually adjustable to allow up to 450 cfm, or 40% of the heat pump's total rated airflow of outside air and includes pressure relief.

► Configuration "D": Motorized Fresh Air Damper with Pressure Relief Ventilation (*Optional*)

Motorized, two position damper (open and closed) includes pressure relief. A 24-volt actuated motor controls the damper. The damper may be controlled from an external input such as a time clock, CO2 sensor, energy management system or a manual switch upon request.

► Configuration "C": Economizer (*Optional*)

The economizer reduces the cost of air conditioning by using outside air when acceptable to cool the room. The factory installed Eubank® economizer has integral pressure relief. On a signal from a thermostat that cooling is required, either mechanical cooling with the compressor or free cooling with the economizer is provided. The Eubank economizer is capable of bringing in outside air equal to 100% of the rated cooling capacity of the unit and has built in pressure relief.

An internal enthalpy controller determines whether the outside air is sufficiently cool and dry to be used with cooling. If suitable, the compressor is locked out and the economizer damper opens to bring in outside air. The temperature at which the economizer opens is adjustable from approximately 55°F (13°C) to 73°F (23°C) at 50% RH. If the outside air becomes too hot or humid, the economizer damper closes completely or to a minimum position and mechanical cooling is activated. When used with minimum position potentiometer (optional), the Eubank® economizer can meet requirements of ASHRAE Std. 62.

Outside Air Ventilation Schedule

Ventilation Package Designator*	Description	Outside Air Capability	Pressure Relief
N	Manual, fixed position damper	0-15% of rated air flow	No
Y	Manual damper, field adjustable	Up to 450 cfm, but not to exceed 40% of the rated air flow of the heat pump.	No
Z	Manual damper, field adjustable	Up to 450 cfm, but not to exceed 40% of the rated air flow of the heat pump.	Yes
D	Motorized, two position damper (open and closed) includes pressure relief. A 24-volt actuated motor controls the damper. The damper may be controlled from an external input such as a time clock, CO2 sensor, energy management system or a manual switch upon request.	Up to 450 cfm, but not to exceed 40% of the rated air flow of the heat pump.	Yes
C	Economizer	100% of rated air flow of outside air	Yes

Heat Pump PC Board

Every Eubank heat pump has a PC board that controls the operation of the indoor blower, the compressor and the reversing valve while providing high refrigerant pressure and loss of refrigerant protection with an integral defrost function. In addition, the board has user selectable pins and potentiometers for multi-function control.

➤ High & Loss of Refrigerant Protection

If either of these fault conditions occur twice within an one hour, the control board will enter into and indicate the lockout mode. In the lockout mode, the compressor will not operate, the alarm output is energized and the red LED will blink to indicate which fault has occurred. The user can select either Normally Open or Normally Closed contacts.

➤ Compressor Anti-Short Cycle Protection

An integral three minute delay prevents compressor from destructive short cycling.

➤ Loss of Refrigerant By-pass Timer

To prevent nuisance fault alarms, the board ignores a loss of charge fault for three minutes on start-up of the compressor.

➤ Defrost Control

The defrost cycle removes ice build-up on the outdoor coil during the heating cycle. If the defrost sensor senses a coil temperature of 32°F while in the heat mode, a 30, 60 or 90 minute (user selectable) delay period will begin. After the delay period if the sensor is still calling for a defrost cycle, the outdoor fan will be stopped and the reversing valve energized. The defrost cycle will stop if the defrost sensor registers a temperature of 50°F or after 10 minutes. By moving the EHDD pin, the user can have electric heat operate during the defrost cycle or not operate.

➤ Electric Heat During Defrost (EHDD)

The control board has an EHDD jumper pin marked YES or NO. When the YES pins are jumped, electric heat WILL operate during a defrost cycle. When the NO pins are jumped, electric heat will NOT operate during a defrost cycle.

Note: When EHDD is set to YES, the S-circuit jumpers must be set to NO.

➤ S-Circuit

The control board has an S-CIRCUIT jumper pin marked YES or NO. When the YES pins are jumped, electric heat will NOT operate with the compressor. When the NO pins are jumped, electric heat WILL operate with the compressor.

Note: When S-Circuit is set to YES, the EHDD jumpers must be set to NO.

➤ Indoor Blower Speed Control

A speed control potentiometer mounted on the board allows the user to vary the blower speed on the EAA heat pumps from 40% to 100% of rated air flow. (Not applicable on models with the electronically commutated indoor blower motor).

➤ Ventilation Damper Relay

The control board has an DRO/DRC jumper pin marked YES and NO. When the YES pins are jumped, the “D” Damper will drive open when the indoor fan operates. When the NO pins are jumped, the “D” Damper will NOT drive open when the indoor fan operates. This control is for two position - Open & Closed motorized fresh air damper (Ventilation Configuration “D”). Independent damper control from an external input such as a time clock, CO2 sensor, energy management system or a manual switch upon request.

Protection of the Refrigerant Components

➤ High Refrigerant Pressure Switch

The high pressure switch is located on the liquid line. It is electrically connected to the PC board and will turn the compressor off if the pressure rises above the set point twice within one hour. This protects the compressor if airflow is significantly reduced or lost through the coil performing the condenser function.

➤ Loss of Charge Switch

The loss of charge switch is located on the liquid line. It is electrically connected to the PC board and will turn the compressor off if the pressure drops below the set point twice within one hour. This protects the compressor if airflow is significantly reduced or lost through the coil performing the evaporator function or there is a loss of refrigerant.

Eubank EAA Heat Pump Options

Eubank® options can be used to provide optimum performance over a full range of operating conditions.

➤ Adjustable Outdoor Thermostat

Will not allow electric resistance heat to be energized unless the outdoor temperature is below the desired set point. Field or factory installed. Available on all EAA units.

➤ Energy Management System (EMS) Relay Kit

Relay to control the unit. Available in 24, 120 or 240 VAC. Field or factory installed.

➤ Electric Reheat

Control provides simultaneous operation of compressor when in cooling mode and the electric elements to provide dehumidification without over cooling the room. The electric element (kW) must be properly sized for each model for proper operation. Factory installed. Available on all EAA units. Consult factory for details.

➤ Compressor Sound Jackets

Reduces sound of compressor.

Special Application Packages and Coil Coatings

➤ Protective Coating Packages

Typically, only non-economizer units are used in corrosive environments, but all Eubank air conditioner are available with corrosion protection. Two corrosion protection packages are offered - one for the condenser section (Coastal Environmental Package) and the other for the entire unit (Coat-All Package).

The Coastal Environmental Package includes:

- Corrosion resistant fasteners
- Sealed or partially sealed condenser fan motor
- Protective coating applied to all exposed internal copper and metal in the condenser section
- Protective coating on the condenser coil (Luvata Insitu®) contains ES2 (embedded stainless steel pigment) technology.

The Coat all Package includes all of the above, plus:

- Protective coating on the evaporator coil (Luvata Insitu®) contains ES2 (embedded stainless steel pigment) technology
- Protective coating on exterior and interior components and sheet metal. (**Note:** the internal sheet metal which is insulated, bottom outside panel, and the internal control box are not coated)

➤ Protective Coil Coatings

The Condenser Coil or the Evaporator Coil or Both can be coated. Coating the Evaporator Coil is not common. For harsh conditions, e.g., power plants, paper mills or sites where the unit will be exposed to salt water, the coils should be protected by a protective coating.

Note: Cooling capacity may be reduced by up to 5% on units with coated coils.

Accessories

➤ Thermostats for Single Stage Heat Pumps (no electric heat)

Digital, Non-Programmable ThermostatP/N 50121
1 stage heat, 1 stage cool. Fan switch: Auto & On. Manual changeover system switch: Cool-Off-Heat. Low temperature protection. °F or °C selectable. Thirty minute power loss memory retention.

Digital, Seven Day Programmable ThermostatP/N 50123
1 stage heat, 1 stage cool. Fan switch: Auto & On. Auto-changeover. Keypad lockout. Non-volatile program memory. Title 24 compliant.

Digital, Non-Programmable ThermostatP/N 50186
 One stage cool/One stage heat. Manual or auto changeover. Fan mode: Auto or On. Permanent retention of settings upon power loss. Field adjustable temperature calibration. Max heat and minimum cool set points. Adjustable temperature differential. Remote sensor capable. Keypad lock out. Status LED. °F or °C selectable.

➤ **Thermostats for Heat Pumps with 2-Stage Heat**

Digital, 7 Day, 5-2 and 5-1-1 Day Programmable Thermostat.....P/N 50107
 Two stage heat/Two stage cool. Manual or auto changeover. Fan: Auto & On. Permanent retention of setting on power loss. Field adjustable temperature calibration. Adjustable max. setpoint for heating and min. adjustable setpoints for cooling. Adjustable temperature differential. Keypad lockout. Status LED. °F or °C selectable. Title 24 compliant.

Digital, 7 Day, 2 Occupied & 2 Unoccupied Periods for Each Day of the Week Programmable Thermostat.....P/N 50248
 Three stage heat/Three stage cool. Manual or auto changeover. Fan: Auto & On. Ten year retention of programming settings and 48 hour clock and day settings on power loss. Adjustable max. setpoint for heating and min. adjustable setpoints for cooling. Adjustable temperature differential. Keypad lockout. Status LED. °F or °C selectable. Optional remote sensors for outdoor air, supply air and humidity. Title 24 compliant.

Digital, Non-Programmable ThermostatP/N 50252
 Two stage heat/Two stage cool. Manual or auto changeover. Fan: Auto & On. Permanent retention of setting on power loss. Field adjustable temperature calibration. Adjustable max. setpoint for heating and min. adjustable setpoints for cooling. Adjustable temperature differential. Keypad lockout. Status LED. °F or °C selectable.

➤ **MAR7000 Thermostat/Controller**

The MAR7000 thermostat/controller is a stand alone, self-programming HVAC controller designed to optimize performance of Eubank’s heat pumps and air conditioners. It can function as an independent controller or be used in conjunction with a BACnet network.

With built-in temperature, humidity sensors, motion sensing and an optional CO2 detection sensor, the MAR7000 can control:

- Temperature and humidity,
- Single or 2-stage air conditioners or heat pumps with supplemental hot water or electric heat,
- Hot gas dehumidification operation,
- An economizer cycle, and
- Eubank’s various ventilation options including the Eubank GreenWheel® Energy Recovery Ventilator.



The intelligent occupancy anticipation feature of the MAR7000 automatically programs occupied and unoccupied settings for temperature, humidity, and ventilation requirements. The ventilation control can be based on occupancy, demand, time, or a combination of these features. When vacant, the thermostat automatically reduces the run time of the unit and adjusts ventilation to save energy. The intelligent occupancy feature can be turned off, and the MAR7000 can be connected to a BACnet control system for remote control and operation of Eubank heat pumps or air conditioners. The MAR7000 thermostat includes a precise, real time clock with capacitor back up to maintain the program and set points for extended power outages.

Features include:

- User-friendly English-language menus (no obscure numeric codes) on a 64 x 128 pixel, dot-matrix LCD display with 5 buttons for data selection and entry,
- Built-in, factory-tested libraries of configurable application control sequences,
- Schedules that can easily be set uniquely by weekdays (Mon.–Fri.), weekend (Sat.–Sun.), entire week (Mon.–Sun.), individual days, and/or holidays,
- Six On/Off and independent heating and cooling set point periods are available per day, and
- Three levels of password-protected access (user/operator/administrator) prevent disruption of operation and configuration

➤ **Thermostat Guards**

Clear Thermostat Guard with Keylock & Clear Plastic Cover & Base.....P/N 50092
 For use with 50121, 50123, 50186, 50107 and 50252 thermostats.

Clear Thermostat Guard with Keylock & Clear Plastic Cover & Base.....P/N 50119
 For use with 50248 thermostat.

➤ **Humidity Controller**

Digital Humidity Controller P/N 50254

To be used with units with Hot Gas or electric reheat. Programmable dehumidistat, ventilation control. Permanent memory retention of set points. Humidity sensor can be field calibrated. High & low dehumidification set points. Outdoor temperature and humidity sensor included. °F or °C selectable.

➤ **Grilles**

Description	Size	Eubank P/N
<i>For the EAA1020H/1024H</i>		
Double Deflection, Aluminum Supply Grille	20" x 8" (509mm x 203mm)	80674
Aluminum Return Grille	20" x 12" (509mm x 305mm)	80677
Return Filter Grille	20" x 12" (509mm x 305mm)	80671
<i>For the EAA1030H/1036H</i>		
Double Deflection, Aluminum Supply Grille	28" x 8" (711mm x 203mm)	80675
Aluminum Return Grille	28" x 14" (711mm x 356mm)	80678
Return Filter Grille*	28" x 14" (711mm x 356mm)	80672
<i>For the EAA1042H/1048H/1060H</i>		
Double Deflection, Aluminum Supply Grille	30" x 10" (762mm x 254mm)	80676
Aluminum Return Grille	30" x 16" (762mm x 406mm)	80679
Return Filter Grille	30" x 16" (762mm x 406mm)	80673
<p>Note: Return filter grilles should be used when the 2" (51mm) filter in the EAA unit is not accessible from the exterior of the building. Filter used in the return filter grille is a 1" (25mm) thick filter. The return filter grille is not recommended for use with the EAA II heat pumps with economizers.</p>		

Eubank Heat Pump Model Identification

Example	E	A	A	1	0	3	6	H	A	0	5	0	C	+	+	+	+	1	E	A	+	A	1	8	+	+	+	+	+	+
Position	1	2	3	4	5	6	7	8	9	10	11	12	13	14	15	16	17	18	19	20	21	22	23	24	25	26	27	28	29	30

1	Unit Designation/Family	E = Eubank Wall Mount S = Stock Unit	17	Indoor Air Quality Features	D = Dry Bulb Sensor E = Dry Bulb Sensor w/Dirty Filter G = Dirty Filter Sensor + = None \$ = Special		
2	Energy Efficiency Ratio (EER)	A = 11	18	Air Flow	1 = Top Supply/Bottom Return \$ = Special		
3	Refrigerant Type	A = R-410a	19	Compressor Location	C = Center - All 6 ton units and above D = Left Hand - All 3 1/2 to 5 ton units E = Right Hand - All 1 1/2 to 3 ton units		
4	Compressor Type/Quantity	1 = Single	20	Filter Option	A = 2" Pleated (MERV 8, AC/HP-C) C = 2" Charcoal D = MERV 11 High Filtration Package E = MERV 13 High Filtration Package F = Filter Access Through Return Air Grille W = Aluminum Washable + = None \$ = Special		
5	Unit Capacity/Nominal Cooling (BTUH)	020 = 20,000 042 = 42,000	21	Corrosion Protection	A = Condenser Coil Only C = Evaporator Coil Only D = Both Coils Condenser & Evaporator E = All Coils Cond/Evap/Reheat F = Coat All G = Coastal Package & Evaporator Coil K = Coastal Package + = None \$ = Special		
6		024 = 24,000 048 = 48,000					
7		030 = 30,000 060 = 60,000	22	Engineering Revision Level	A1		
8	System Type	H = Heat Pump	23	Cabinet Color	1 = Marvailr Beige 2 = Gray 3 = Carlsbad Canyon 4 = White 5 = Stainless Steel Exterior 6 = Dark Bronze 7 = .050 Aluminum Stucco 8 = Mesa Tan 9 = Pebble Gray A = Stainless Steel - Unit \$ = Custom Color (Powder Coat)		
9	Power Supply (Volts-Phase-Hz)	A = 208/230-1-60 D = 460-3-60 C = 208/230-3-60	24			Sound Attenuation	2 = Compressor Blanket + = None
10	Heat Designation @ Rated Voltage	000 = No Heat 090 = 9KW	25			Security Option	A = Lockable Access Plate/Tamper Proof C = Tamper Proof Screws D = Lockable Access Plate w/Tamper Proof + = None \$ = Special
11		040 = 4KW 100 = 10KW					
12		050 = 5KW 120 = 12KW	26	Fastener/Drain Pan Option	A = Stainless Steel Fasteners C = Stainless Steel Drain Pan D = Stainless Steel Fasteners & Drain Pan + = None \$ = Special		
13	Ventilation Configuration	N = Barometric Damper w/15% OSA Y = Manual Damper w/No Pressure Relief Z = Manual Damper w/Pressure Relief D = Motorized Damper w/Pressure Relief C = Economizer + = None \$ = Special					
14	Dehumidification	R = Electric Reheat T = Electric Reheat w/Humidity Control + = None \$ = Special	27	Unused	+ = None \$ = Special		
15	Controls	A = Power Fail Alarm w/Additional Lockouts C = 24V EMS Relay Kit D = 24V EMS Relay Kit w/Factory Installed T-Stat E = Factory Installed T-Stat + = None \$ = Special	28	Unused	+ = None \$ = Special		
16	Operating Condition	A = Evaporator Freeze Sensor (EFS) C = EFS w/Hot Gas Bypass D = Desert Duty E = Extreme Duty F = Desert Duty w/Hard Start G = Desert Duty w/EFS H = Desert Duty w/Hard Start & EFS J = Extreme Duty w/Hard Start K = Extreme Duty w/EFS M = Extreme Duty w/Hard Start & EFS N = Hard Start P = Hard Start w/Low Ambient & CCH Q = Hard Start w/Low Ambient & Fan Cycle Control (FCC) R = Crank Case Heater (CCH) T = Hard Start w/EFS U = Hard Start w/Hot Gas Bypass V = Hard Start w/Low Ambient & CCH & EFS W = Low Ambient w/CCH X = Hot Gas Bypass Y = Low Ambient w/CCH & FCC Z = Low Ambient w/CCH & EFS 1 = Low Ambient w/FCC 2 = Low Ambient w/FCC & EFS 3 = CCH w/Hot Gas Bypass + = None \$ = Special	29	Special Variation	+ = None \$ = Special Configuration Not Covered by Model Nomenclature		

Note: Not all options are available with all configurations. Contact your Eubank sales representative for configuration details and feature compatibility.

EER Comparison by Model

Nominal Cooling Capacity (BTUH)	Basic Model	EER	Nominal Cooling Capacity (BTUH)	Basic Model	EER
20,000	EAA1020H	11.00	42,000	EAA1042H	11.00
24,000	EAA1024H	11.00	48,000	EAA1048H	11.00
30,000	EAA1030H	11.00	60,000	EAA1060H	11.00
36,000	EAA1036H	11.00			

Eubank EAA Heat Pump Certified Ratings & Performance

Certified Efficiency and Capacity Ratings at ANSI/AHRI Standard 390 - EAA Heat Pumps

Model Number	EAA1020H	EAA1024H			EAA1030H			EAA1036H			EAA1042H			EAA1048H			EAA1060H		
	A	A	C	D	A	C	D	A	C	D	A	C	D	A	C	D	A	C	D
Cooling BTUH¹	20,000	24,000			29,000			35,000			42,000			46,000			57,000		
EER²	11.00	11.00			11.00			11.00			11.00			11.00			11.00		
High Temperature Heating³	20,000	24,000			30,000			35,000			34,000			42,000			51,000		
High Temperature COP⁴	3.30	3.30			3.30			3.30			3.30			3.30			3.30		
Rated Air Flow (CFM⁵)	800	820			1,000			1,200			1,350			1,600			1,750		

¹Cooling is rated at 95°F (35°C) outdoor and 80°F DB/67°F WB (26.5°C DB/19.5°C WB) return air.

²EER = Energy Efficiency Ratio

³High Temperature Heating & COP are rated at 47°F DB/43°WB (8.3°C DB/6.1°C WB) outdoor and 70°F (21.1°C) return air.

⁴COP = Coefficient of Performance

⁵CFM = Cubic Feet per Minute

Ratings are with no outside air. Performance will be affected by altitude. Ratings are at 230 volts for 208/230 volt units ("A" & "C" models) and 460 volts for "D" models.

Operation of units at a different voltage from that of the rating point will affect performance and air flow.

Sensible Total Heat Ratio @ 95°F (35°C) Outside Air DB - EAA Heat Pumps

Model Number	EAA1020H	EAA1024H			EAA1030H			EAA1036H			EAA1042H			EAA1048H			EAA1060H		
	A	A	C	D	A	C	D	A	C	D	A	C	D	A	C	D	A	C	D
Total Capacity	20,000	24,000			29,000			35,000			42,000			46,000			57,000		
Sensible Heat Ratio	0.75	0.78			0.74			0.70			0.70			0.72			0.67		
Sensible Capacity	15,000	18,770			21,385			24,560			29,545			33,060			38,200		
Rated Air Flow (CFM¹)	800	820			1,000			1,200			1,350			1,600			1,750		

¹CFM=Cubic Feet per Minute

Sensible Heat Ratios based upon ANSI/AHRI std. 390 outdoor conditions of 95°F (35°C) outdoor and 80°F DB/67°F WB (26.5°C DB/19.5°C WB) return air.

Cooling Performance (BTUH) at Various Outdoor Temperatures - EAA Heat Pumps

Model Number	Outdoor Temperature									
	75°F/24°C	80°F/26.5°C	85°F/29°C	90°F/32°C	95°F/35°C	100°F/38°C	105°F/40.5°C	110°F/43.3°C	115°F/46°C	
EAA1020H	23,200	22,400	21,600	20,800	20,000	19,200	18,400	17,600	17,200	
EAA1024H	27,840	26,880	25,920	24,960	24,000	23,040	22,080	21,120	20,640	
EAA1030H	33,640	32,480	31,320	30,160	29,000	27,840	26,680	25,520	24,940	
EAA1036H	40,600	39,200	37,800	36,400	35,000	33,600	32,200	30,800	30,100	
EAA1042H	48,720	47,040	45,360	43,680	42,000	40,320	38,640	36,960	36,120	
EAA1048H	53,360	51,520	49,680	47,840	46,000	44,160	42,320	40,480	39,560	
EAA1060H	66,120	63,840	61,560	59,280	57,000	54,720	52,440	50,160	49,020	

Based upon ANSI/AHRI std. 390 return air conditions of 80°F DB/67°F WB (26.5°C DB/19.5°C WB). Return air at rated air flow.

Heating Performance (BTUH) at Various Outdoor Temperatures - EAA Heat Pumps

Model Number	Outdoor Temperature									
	10°F/-12.2°C	17°F/-8.3°C	20°F/-6.7°C	30°F/-1.1°C	40°F/4.4°C	47°F/8.3°C	50°F/10°C	60°F/15.6°C	70°F/21.1°C	
EAA1020H	10,766	11,333	12,200	15,233	17,833	20,000	20,600	21,500	22,500	
EAA1024H	11,560	13,600	14,640	18,280	21,400	24,000	24,720	25,800	27,000	
EAA1030H	15,130	17,800	19,020	23,290	26,950	30,000	30,900	32,250	33,750	
EAA1036H	15,810	18,600	20,240	25,980	30,900	35,000	36,050	37,625	39,375	
EAA1042H	18,700	22,000	23,200	27,400	31,000	34,000	35,020	36,550	38,250	
EAA1048H	20,400	24,000	25,800	32,100	37,500	42,000	43,260	45,150	47,250	
EAA1060H	23,800	28,000	30,300	38,350	45,250	51,000	52,530	54,825	57,375	

Based upon ANSI/AHRI std. 390 return air conditions of 70°F DB (21.1°C DB). Return air at rated air flow.

Air Flow (Cubic Feet per Minute)

Model Number	External Static Pressure (WET COIL)					
	0.10	0.20	0.25	0.30	0.40	0.50
EAA1020H/1024H	860	810	740	670		
EAA1030H	1100	1000	960	920	810	
EAA1036H	1310	1220	1185	1150	1060	
EAA1042H		1650	1585	1520	1450	1360
EAA1048H		1900	1830	1760	1700	1620
EAA1060H		2100	2000	1900	1800	1650

Air flow ratings of 208-230v. Units are at 230v. Air flow ratings of 480 v. units are at 460 volts. Operation of units at a different voltage from the rating point will affect air flow.

Electrical Characteristics - Compressor, Fan, Ventilation & Blower Motors

Model Number	COMPRESSOR			OTHER MOTORS	OUTDOOR FAN MOTOR			INDOOR BLOWER MOTOR		
	VOLTS-HZ-PH	RLA ¹	LRA ²	VOLTS-HZ-PH	RPM ³	FLA ⁴	HP ⁵	RPM ³	FLA ⁴	HP ⁵
EAA1020HA	208/230-60-1	10.9	62.9	208/230-60-1	1200	3.5	1/3	1500	2.8	1/3
EAA1024HA	208/230-60-1	12.8	67.8	208/230-60-1	1200	3.5	1/3	1500	2.8	1/2
EAA1030HA	208/230-60-1	14.1	72.2	208/230-60-1	1200	3.5	1/3	1200	4.3	1/2
EAA1036HA	208/230-60-1	16.7	109.0	208/230-60-1	1200	3.5	1/3	1050	4.3	1/2
EAA1042HA	208/230-60-1	17.0	123.9	208/230-60-1	1200	5.3	1/2	1050	4.3	1/2
EAA1048HA	208/230-60-1	19.5	130.0	208/230-60-1	1200	5.3	1/2	1050	6.8	3/4
EAA1060HA	208/230-60-1	24.3	144.2	208/230-60-1	1200	5.3	1/2	1050	6.8	3/4
EAA1024HC	208/230-60-3	8.3	58.0	208/230-60-1	1200	3.5	1/3	1500	2.8	1/3
EAA1030HC	208/230-60-3	9.0	71.0	208/230-60-1	1200	3.5	1/3	1200	4.3	1/2
EAA1036HC	208/230-60-3	11.2	84.0	208/230-60-1	1200	3.5	1/3	1200	4.3	1/2
EAA1042HC	208/230-60-3	13.6	83.1	208/230-60-1	1200	5.3	1/2	1050	4.3	1/2
EAA1048HC	208/230-60-3	13.7	83.1	208/230-60-1	1200	5.3	1/2	1050	6.8	3/4
EAA1060HC	208/230-60-3	15.9	110.0	208/230-60-1	1200	5.3	1/2	1050	6.8	3/4
EAA1024HD	460-60-3	3.5	28.0	208/230-60-1	1200	3.5	1/3	1500	2.8	1/2
EAA1030HD	460-60-3	5.8	38.0	208/230-60-1	1200	3.5	1/3	1200	4.3	1/2
EAA1036HD	460-60-3	5.6	44.0	208/230-60-1	1200	3.5	1/3	1050	4.3	1/2
EAA1042HD	460-60-3	6.1	41.0	208/230-60-1	1200	5.3	1/2	1050	4.3	1/2
EAA1048HD	460-60-3	6.2	41.0	208/230-60-1	1200	5.3	1/2	1050	6.8	3/4
EAA1060HD	460-60-3	7.7	52.0	208/230-60-1	1200	5.3	1/2	1050	6.8	3/4

¹RLA = Rated Load Amps ²LRA = Locked Rotor Amps ³RPM = Revolutions per Minute ⁴FLA = Full Load Amps ⁵HP = Horsepower
⁶OAM = Outside Air Mover ⁷EXM = Exhaust Air Mover ⁸WD = Wheel Drive Motor

The 460 volt units have a step down transformer for the 230 volt motors.

EAA Heat Pumps Summary Electrical Ratings (Wire and HACR Circuit Breaker Sizing) - Ventilation Configuration:

Manual Damper, up to 15% outside air (“N”), Manual Damper, up to 450 cfm of outside air (“Y”)
 Manual Damper, up to 450 cfm of outside air with pressure relief (“Z”)
 Motorized 2-Position Damper, up to 450 cfm of outside air w/Pressure Relief (“D”)
 Economizer, Outside air with Pressure Relief (“C”)

ELECTRIC HEAT		000 = None		040 = 4 kw		050 = 5 kw		060 = 6 kw		080 = 8 kw		090 = 9 kw		100 = 10 kw		120 = 12 kw		150 = 15 kw	
BASIC MODEL	VOLTS-HZ-PH	SPPE ³		SPPE ³		SPPE ³		SPPE ³		SPPE ³		SPPE ³		SPPE ³		SPPE ³		SPPE ³	
		MCA ¹	MFS ²	MCA ¹	MFS ²	MCA ¹	MFS ²	MCA ¹	MFS ²	MCA ¹	MFS ²	MCA ¹	MFS ²	MCA ¹	MFS ²	MCA ¹	MFS ²	MCA ¹	MFS ²
EAA1020HA	208/230-1-60	19.9	30	40.8	45	46.0	50	46.0	60	61.6	70			72.0	80				
EAA1024HA	208/230-1-60	22.3	35	43.1	45	48.3	50	48.3	60	64.0	70			74.4	80				
EAA1030HA	208/230-1-60	25.4	35	46.3	50	51.5	60	51.5	60	67.1	70			77.5	80	87.9	90	103.6	110
EAA1036HA	208/230-1-60	28.7	45	49.5	50	54.7	60	54.7	70	70.3	80			80.8	90	91.2	100	106.8	110
EAA1042HA	208/230-1-60	30.9	45			56.9	60							82.9	90	93.4	100	109.0	110
EAA1048HA	208/230-1-60	36.5	60			62.5	70							88.6	90	99.0	100	114.6	120
EAA1060HA	208/230-1-60	42.5	60			68.5	70							94.6	100	105.0	110	120.6	130
EAA1024HC	208/230-3-60	16.7	25					34.7	35			43.7	45			52.8	60	61.8	70
EAA1030HC	208/230-3-60	19.1	25					37.1	40			46.1	50			55.1	60	64.2	70
EAA1036HC	208/230-3-60	21.8	30					39.8	40			48.9	50			57.9	60	66.9	70
EAA1042HC	208/230-3-60	26.6	40					44.6	45			53.7	60			62.7	70	71.7	80
EAA1048HC	208/230-3-60	29.2	40					47.3	50			56.3	60			65.3	70	74.3	80
EAA1060HC	208/230-3-60	32.0	45					50.0	60			59.0	60			68.1	70	77.1	80
EAA1024HD	460-3-60	7.5	15					16.5	20			21.1	25			25.6	30	30.1	35
EAA1030HD	460-3-60	11.2	15					20.2	25			24.7	25			29.2	30	33.7	35
EAA1036HD	460-3-60	10.9	15					19.9	25			24.4	25			28.9	30	33.5	35
EAA1042HD	460-3-60	12.4	15					21.4	25			26.0	30			30.5	35	35.0	40
EAA1048HD	460-3-60	13.8	15					22.8	25			27.3	30			31.8	35	36.4	40
EAA1060HD	460-3-60	15.7	20					24.7	25			29.2	30			33.7	35	38.2	40

S-Circuit - The user can move a pin on the board to control whether the electric heat will operate simultaneously with the compressor (S Circuit – NO) or will not run simultaneously with the compressor (S Circuit – Yes).
¹MCA = Minimum Circuit Ampacity (Wiring Size Amps) ²MFS = Maximum Fuse or HACR Breaker Size ³SPPE = Single Point Power Entry
 MCA & MFS are calculated at 230 volts on the 208-230v. (HPA & HPC) models. The 460 volt HPD models are calculated at 460 volts. This chart should only be used as a guideline for estimating conductor size and overcurrent protection. For the requirements of specific units, always refer to the data label on the unit.

EAA Heat Pumps Summary Electrical Ratings (Wire and HACR Circuit Breaker Sizing) - EAA Heat Pumps with the “S” Circuit Jumper Set to “Yes” and Ventilation Configuration:

Manual Damper, up to 15% outside air (“N”), Manual Damper, up to 450 cfm of outside air (“Y”)
 Manual Damper, up to 450 cfm of outside air with pressure relief (“Z”)
 Motorized 2-Position Damper, up to 450 cfm of outside air w/Pressure Relief (“D”)
 Economizer, Outside air with Pressure Relief (“C”)

ELECTRIC HEAT		000 = None		040 = 4 kw		050 = 5 kw		060 = 6 kw		080 = 8 kw		090 = 9 kw		100 = 10 kw		120 = 12 kw		150 = 15 kw	
BASIC MODEL	VOLTS-HZ-PH	SPPE ³		SPPE ³		SPPE ³		SPPE ³		SPPE ³		SPPE ³		SPPE ³		SPPE ³		SPPE ³	
		MCA ¹	MFS ²	MCA ¹	MFS ²	MCA ¹	MFS ²	MCA ¹	MFS ²	MCA ¹	MFS ²	MCA ¹	MFS ²	MCA ¹	MFS ²	MCA ¹	MFS ²	MCA ¹	MFS ²
EAA1020HA	208/230-1-60	19.9	30	23.6	30	28.8	30	34.1	35	44.5	45			54.9	60				
EAA1024HA	208/230-1-60	22.3	35	23.6	35	28.8	35	34.1	35	44.5	45.0			54.9	60				
EAA1030HA	208/230-1-60	25.4	35	25.1	35	30.3	35	35.6	40	46.0	50			56.4	60	66.8	70	82.4	90
EAA1036HA	208/230-1-60	28.7	45	25.1	45	30.3	45	35.6	40	46.0	50			56.4	60	66.8	70	82.4	90
EAA1042HA	208/230-1-60	30.9	45			30.3	45							56.4	60	66.8	70	82.4	90
EAA1048HA	208/230-1-60	36.5	60			32.8	60							58.9	60	69.3	70	84.9	90
EAA1060HA	208/230-1-60	42.5	60			32.8	60							58.9	60	69.3	70	84.9	90
EAA1024HC	208/230-3-60	16.7	25					20.8	25			29.9	30			38.9	40	47.9	50
EAA1030HC	208/230-3-60	19.1	25					22.3	25			31.4	35			40.4	45	49.4	50
EAA1036HC	208/230-3-60	21.8	30					22.3	30			31.4	35			40.4	45	49.4	50
EAA1042HC	208/230-3-60	26.6	40					22.3	40			31.4	40			40.4	45	49.4	50
EAA1048HC	208/230-3-60	29.2	40					24.8	40			33.9	40			42.9	45	51.9	60
EAA1060HC	208/230-3-60	32.0	45					24.8	45			33.9	45			42.9	45	51.9	60
EAA1024HD	460-3-60	7.5	15					10.4	15			14.9	25			19.4	20	24.0	25
EAA1030HD	460-3-60	11.2	15					11.2	15			15.7	20			20.2	25	24.7	25
EAA1036HD	460-3-60	10.9	15					11.2	15			15.7	20			20.2	25	24.7	25
EAA1042HD	460-3-60	12.4	15					11.2	15			15.7	20			20.2	25	24.7	25.0
EAA1048HD	460-3-60	13.8	15					12.4	15			16.9	20			21.4	25	26.0	30
EAA1060HD	460-3-60	15.7	20					12.4	20			16.9	20			21.4	25	26	30

S-Circuit - The user can move a pin on the board to control whether the electric heat will operate simultaneously with the compressor (S Circuit – NO) or will not run simultaneously with the compressor (S Circuit – Yes).
¹MCA = Minimum Circuit Ampacity (Wiring Size Amps) ²MFS = Maximum Fuse or HACR Breaker Size ³SPPE = Single Point Power Entry
 MCA & MFS are calculated at 230 volts on the 208-230v. (HPA & HPC) models. The 460 volt HPD models are calculated at 460 volts. This chart should only be used as a guideline for estimating conductor size and overcurrent protection. For the requirements of specific units, always refer to the data label on the unit.

Unit Load Amps (Heating) -

EAA Heat Pumps with Ventilation Configurations:

Manual Damper, up to 15% outside air (“N”), Manual Damper, up to 450 cfm of outside air (“Y”)

Manual Damper, up to 450 cfm of outside air with pressure relief (“Z”)

Motorized 2-Position Damper, up to 450 cfm of outside air w/Pressure Relief (“D”)

Economizer, Outside air with Pressure Relief (“C”)

MODEL NUMBER	VOLTAGE PHASE HERTZ	CURRENT (AMPS)		LOAD OF RESISTIVE HEATING - ELEMENTS ONLY (AMPS)								TOTAL MAXIMUM HEATING AMPS								
		HP ¹	IBM ²	(1) ALL HEATING ELEMENTS ARE ON A SEPARATE CIRCUIT								INCLUDES AMPS FROM MOTOR(S) THAT ARE LOCATED ON AN ELECTRICAL CIRCUIT THAT DOES NOT HAVE HEATERS								
				(2) SHADED VALUES (12 & 15 kW) UTILIZE TWO CIRCUITS																
04 kW	05 kW	06 kW	08 kW	09 kW	10 kW	12 kW	15 kW	04 Kw	05 Kw	06 Kw	08 Kw	09 Kw	10 Kw	12 Kw	15 Kw					
EAA1020HA	208-230/1/60	17.2	2.8	16.7	20.8	25.0	33.3		41.7				19.5	23.6	27.8	36.1		44.5		
EAA1024HA	208-230/1/60	19.1	2.8	16.7	20.8	25.0	33.3		41.7				19.5	23.6	27.8	36.1		44.5		
EAA1030HA	208-230/1/60	21.9	4.3	16.7	20.8	25.0	33.3		41.7	50.0	62.5		21.0	25.1	29.3	37.6		46.0	54.3	66.8
EAA1036HA	208-230/1/60	24.5	4.3	16.7	20.8	25.0	33.3		41.7	50.0	62.5		21.0	25.1	29.3	37.6		46.0	54.3	66.8
EAA1042HA	208-230/1/60	26.6	4.3		20.8				41.7	50.0	62.5		25.1					46.0	54.3	66.8
EAA1048HA	208-230/1/60	31.6	4.3		20.8				41.7	50.0	62.5		25.1					46.0	54.3	66.8
EAA1060HA	208-230/1/60	36.4	6.8		20.8				41.7	50.0	62.5		27.6					48.5	56.8	69.3
EAA1024HC	208-230/3/60	14.6	2.8			14.4		21.7		28.9	36.1				17.2		24.5		31.7	38.9
EAA1030HC	208-230/3/60	16.8	4.3			14.4		21.7		28.9	36.1				18.7		26.0		33.2	40.4
EAA1036HC	208-230/3/60	19.0	4.3			14.4		21.7		28.9	36.1				18.7		26.0		33.2	40.4
EAA1042HC	208-230/3/60	23.2	4.3			14.4		21.7		28.9	36.1				18.7		26.0		33.2	40.4
EAA1048HC	208-230/3/60	25.8	4.3			14.4		21.7		28.9	36.1				18.7		26.0		33.2	40.4
EAA1060HC	208-230/3/60	28.0	6.8			14.4		21.7		28.9	36.1				21.2		28.5		35.7	42.9
EAA1024HD	460/3/60	6.7	1.4			7.2		10.8		14.4	18.0				8.6		12.2		15.8	19.4
EAA1030HD	460/3/60	9.7	2.2			7.2		10.8		14.4	18.0				9.4		13.0		16.6	20.2
EAA1036HD	460/3/60	9.5	2.2			7.2		10.8		14.4	18.0				9.4		13.0		16.6	20.2
EAA1042HD	460/3/60	10.9	2.2			7.2		10.8		14.4	18.0				9.4		13.0		16.6	20.2
EAA1048HD	460/3/60	12.3	2.2			7.2		10.8		14.4	18.0				9.4		13.0		16.6	20.2
EAA1060HD	460/3/60	13.8	3.4			7.2		10.8		14.4	18.0				10.6		14.2		17.8	21.4

¹HP = Heat Pump Unit Amps (includes Indoor Motor amps) ²IBM = Indoor Blower Motor
 Heating kW is rated at 240 volts on the 208-230v. (HPA & HPC) models. Derate heater output by 25% for operation at 208 volts. Heating kW is rated at 480 volts on the HPD models.
 Total heating amps for single phase units with two circuits (#1 and #2) includes both circuits. Total heating and cooling amps includes all motors. Three phase models contain single phase motor loads. Values shown are maximum phase loads. Loads are not equally balanced on each phase.

Eubank EAA Heat Pump Model & Cabinet Designation

MODEL	CABINET DESIGNATION			
	A	B	C	D
EAA1020H/1024H	✓			
EAA1030H/1036H		✓		
EAA1042H/1048H			✓	
EAA1060H				✓

Dimensional Data for Cabinet A (inches and mm)

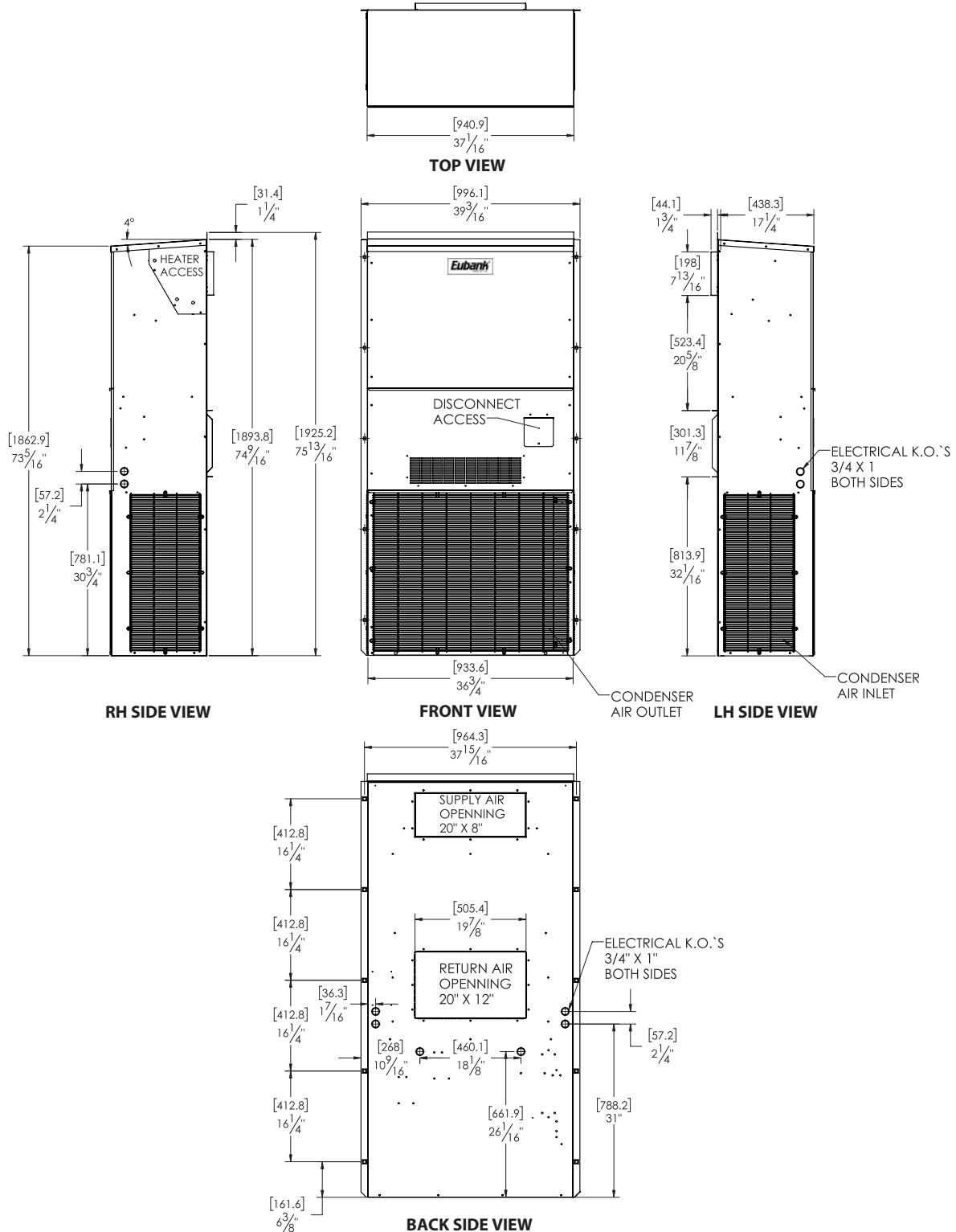

Installation Weight

EAA1020H/1024H	Base	w/Economizer	w/3 Phase	w/Economizer & 3 Phase
Pounds	337	357	356	376
Kilograms	153	162	161	171

Filter Size

EAA1020H/1024H	INCHES	MILLIMETERS	PART NUMBER	FILTERS PER UNIT	MERV RATING
RETURN AIR FILTER	30 x 16 x 2	762 x 406 x 51	80138	1	8

Dimensional Data for Cabinet B (inches and mm)

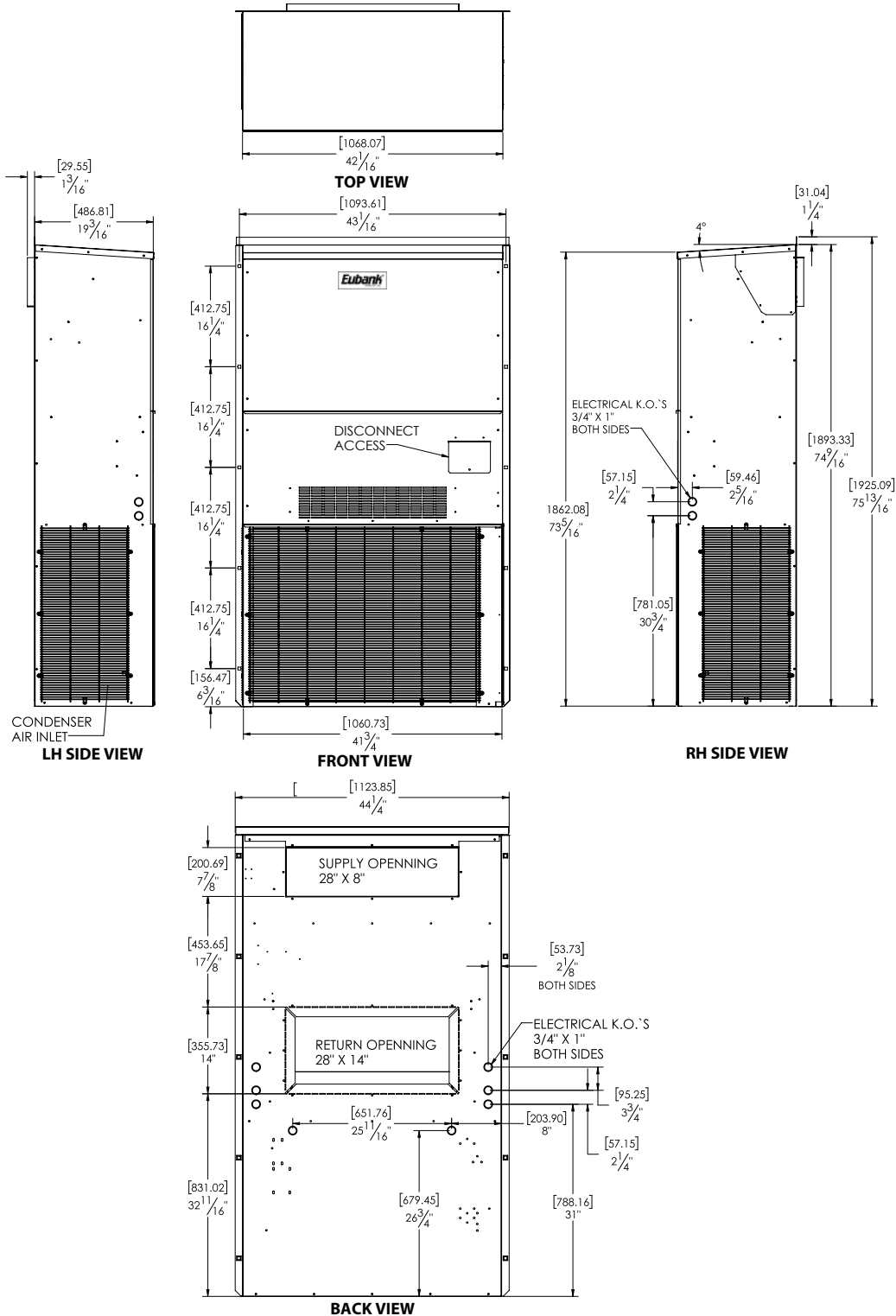

Installation Weight

EAA1030H & EAA1036H	Base	w/Economizer	w/3 Phase	w/Economizer & 3 Phase
Pounds	397	419	416	438
Kilograms	180	190	189	199

Filter Size

EAA1030H & EAA1036H	INCHES	MILLIMETERS	PART NUMBER	FILTERS PER UNIT	MERV RATING
RETURN AIR FILTER	36 1/2 x 22 x 2	927 x 559 x 51	80162	1	8

Dimensional Data for Cabinet C (inches and mm)

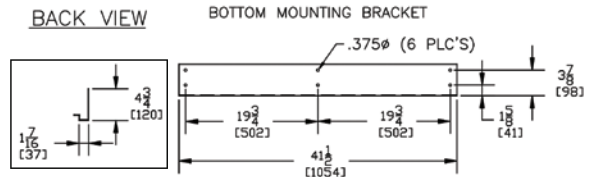
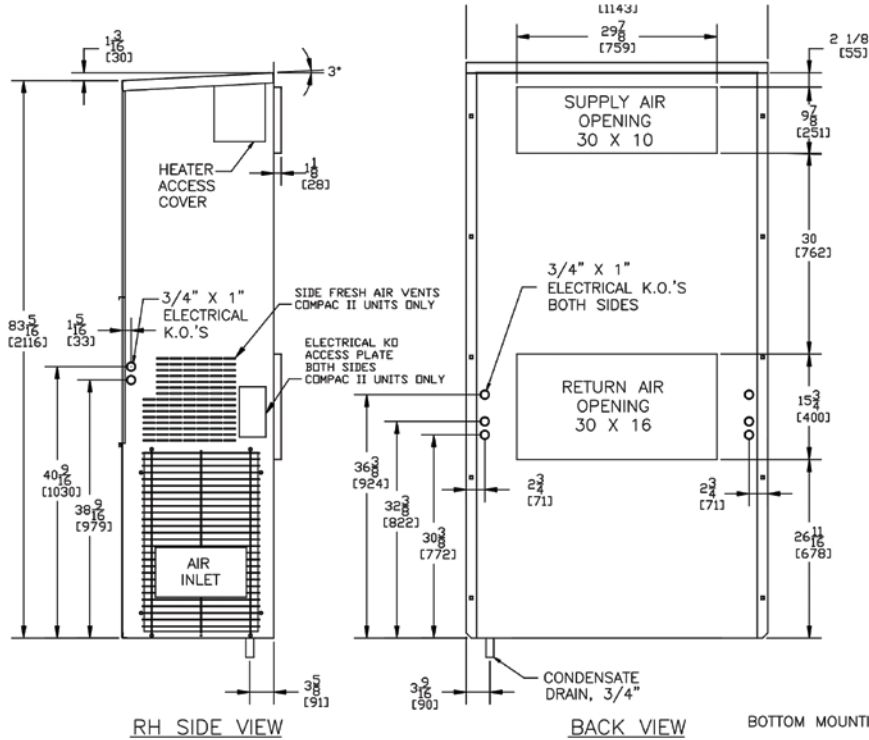
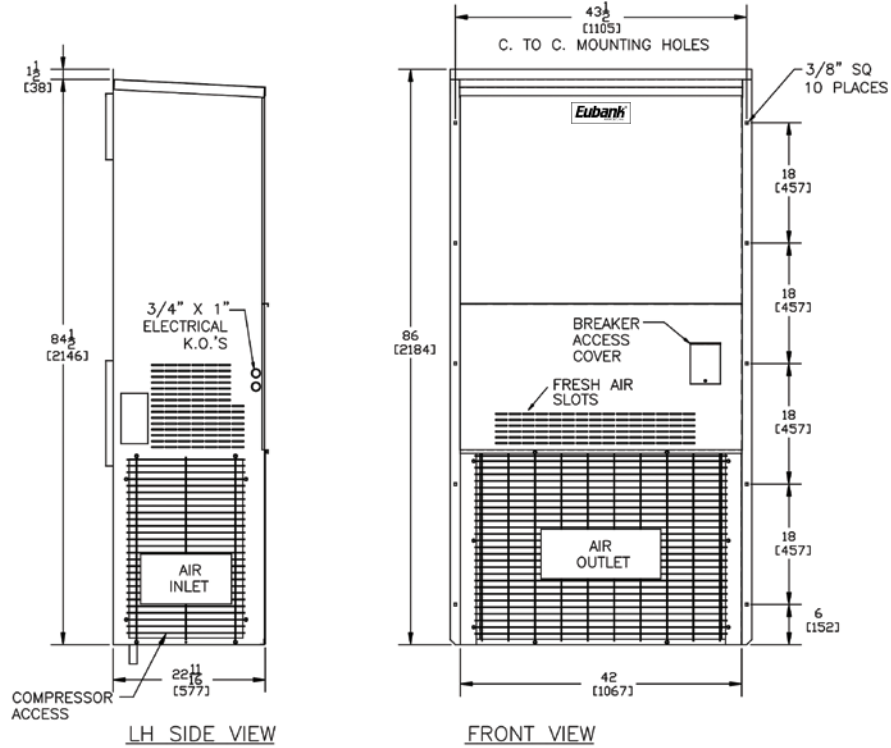

Installation Weight

EAA1042H & EAA1048H	Base	w/Economizer	w/3 Phase	w/Economizer & 3 Phase
Pounds	453	476	491	514
Kilograms	205	216	223	233

Filter Size

EAA1042H & EAA1048H	INCHES	MILLIMETERS	PART NUMBER	FILTERS PER UNIT	MERV RATING
RETURN AIR FILTER	36 1/2 x 22 x 2	927 x 559 x 51	80162	1	8

Dimensional Data for Cabinet D (inches and mm)

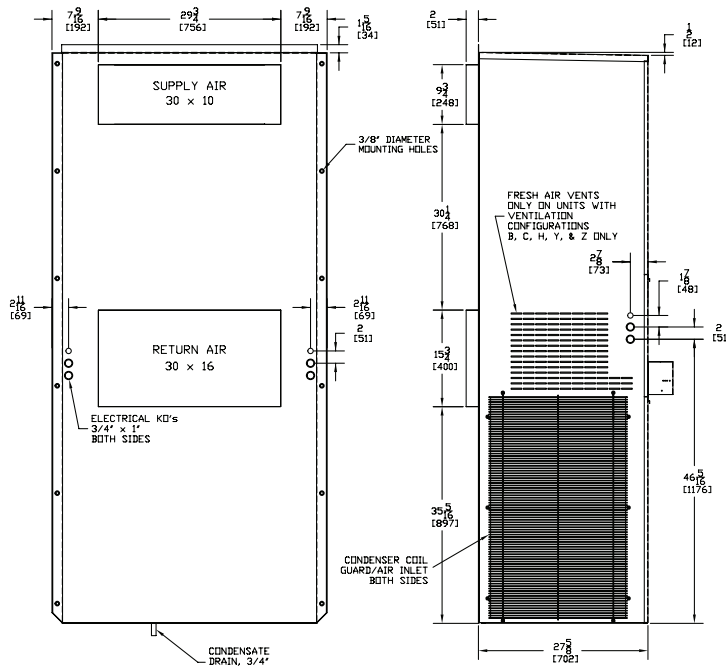

REAR VIEW

LH SIDE VIEW

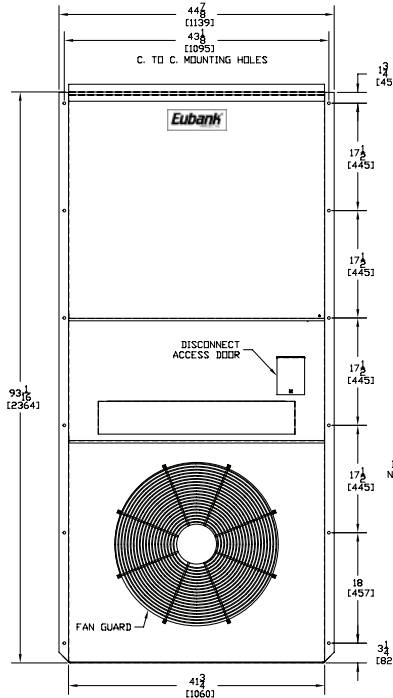

FRONT VIEW

COMPRESSOR ACCESSED FROM FRONT

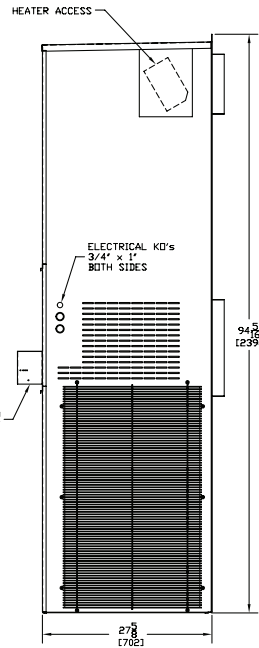

RH SIDE VIEW

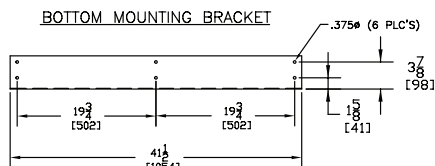
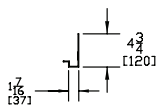

Shipping Weight (pounds/kilograms)

EAA1060H	LBS/KGS
WITH VENTILATION CONFIGURATION "N"	680/309
WITH VENTILATION CONFIGURATION "C", "D", "Y", & "Z"	659/298.9

Filter Size

EAA1060H	INCHES	MILLIMETERS	PART NUMBER	FILTERS PER UNIT	MERV RATING
RETURN AIR FILTER	18 x 24 x 1	457 x 610 x 25	81199	2	8
INTAKE AIR FILTER*	14 x 14 x 1	356 x 356 x 25	80192	1	N/A

Notes

Please consult the Eubank® website at www.EubankWallmount.com for the latest product literature. Detailed dimensional data is available upon request. A complete warranty statement can be found in each product's Installation/Operation Manual, on our website or by contacting Eubank at 229-273-3636. As part of the Eubank continuous improvement program, specifications are subject to change without notice.



P.O. Box 400 • Cordele, GA 31010
156 Seedling Drive • Cordele, GA 31015
Ph: 229-273-3636 • Fax: 229-273-5154
Email: EubankOrders@airxcel.com • Internet: www.EubankWallmount.com

